



Installation Manual
Crystalline module WSP and WST series

1. INTRODUCTION	1
Information for operators	1
Exclusion clause.....	1
2. PRODUCT DESCRIPTION	2
3. WARNING NOTICES AND HANDLING INSTRUCTIONS.....	4
Product protection	5
4. TRANSPORT, STORAGE AND UNPACKING	5
Transport and storage	5
Unpacking	6
5. APPLICATION AREA AND MOUNTING SITE	6
Application area	6
Mounting site.....	6
6. MOUNTING AND INSTALLATION	7
Safety precautions	7
Fire protection	7
6.1 Mechanical module mounting.....	7
Maximum mechanical load	8
Note	8
Laying the cables.....	9
6.2 Electrical installation.....	9
Module selection.....	9
Diodes and fuses	9
Cables and connectors	10
Safety precautions	11
6.3 Grounding.....	11
7. CLEANING AND MAINTENANCE.....	12
8. LIABILITY DISCLAIMER	13
9. CONTACTS	13
Win Win Precision Technology Co., Ltd.	13
WINAICO UK Ltd.	13
WINAICO Australia Pty Ltd	14
WINAICO USA.....	14
WINAICO Japan KK	14

This document applies to the WINAICO WSP and WST series and takes the place of all previous versions of the installation and mounting instructions for these modules.

No responsibility is accepted for the correctness of this information. We reserve the right to technical changes. The documentation in place at the time the module was manufactured applies when undertaking installation, mounting and maintenance work.

1. Introduction

Specialist dealers and installation engineers should read through these instructions carefully prior to the installation, maintenance and operation of our WINAICO WSP and WST series. Carefully adhering to the instructions will ensure that the photovoltaic system delivers the maximum yield during operation on a long-term basis. Failure to observe these instructions can lead to personal injury and damage to property. WINAICO only sells its high-quality modules to specialist companies and installation engineers through direct sales. WINAICO solar modules may only be installed by such specialists. During the mounting process it is necessary to adhere to the applicable valid standards (VDE, VDEW, DIN, TAB, National Electrical Code, building regulations, accident prevention, etc.). All work on photovoltaic systems requires the appropriate specialist knowledge and must therefore be undertaken by authorised specialist personnel exclusively. Unqualified persons must be kept at a distance, in particular children. Please keep the mounting instructions on hand at all times.

Information for operators

Keep these instructions available for the duration of the module's life. Pay particular attention to the chapters on TRANSPORT, STORAGE AND UNPACKAGE, and CLEANING AND MAINTENANCE.

Before installing the solar system, be sure to contact your local authorities and energy suppliers for the relevant guidelines and approval requirements. You will only ensure the conditions required for long-term system operation if you take these requirements into account.

We recommend that you insure your WINAICO photovoltaic system from natural hazards (e.g. lightning strikes).

Exclusion clause

These instructions only apply to WINAICO products. WINAICO does not accept liability for any damage resulting from failure to observe the requirements listed. Please note that the person mounting the system is responsible for connecting and sizing the system as well as compliance with all the safety specifications applicable to configuration and installation. WINAICO assumes no responsibility beyond the proper function and safety of the modules. Also note the installation instructions for other system components which may form part of the overall system. A structural analysis may have to be produced for the entire project.

Please consult our website www.winaico.com for more details.

2. Product description

Module series	WSP-MX 6x10	WST-P6 6x12	WSP-P6 6x10	WSP-M6 6x10
Dimensions (mm)	1,705 x 1028 x 35	1,983 x 999 x 39.4	1,665 x 999 x 39.4	1,665 x 999 x 39.4
Cell type	Monocrystalline	Polycrystalline	Polycrystalline	Monocrystallin
Area (m²)	1.75	1.98	1.66	1.66
Weight (kg)	20.6	23.0	19.6	19.6
Max system voltage (VDC)	1000	1000	1000	1000
Connection type	MC4 (PV-KBT4/PV-KST4) IP68; QC4.10 IP67			
Junction box	IP 67	IP 67	IP 67	IP 67
Fire class	C	C	C	C
Module fire performance	Type 4	Type 4	Type 4	Type 4
Design Load(Pa)	3600	3600	3600	3600
Max Test Load(Pa)	5400	5400	5400	5400

Module series	WST-P6 6X10	WST-M6 6x10	WST-M6 6X8
Dimensions (mm)	1,665 x 999 x 35	1,665 x 999 x 35	1,347 x 999 x 35
Cell type	Polycrystalline	Monocrystalline	Monocrystalline
Area (m²)	1.66	1.66	1.34
Weight (kg)	18.6	18.6	15.1
Max system voltage (VDC)	1000	1000	1000
Connection type	MC4 (PV-KBT4/PV-KST4) IP68; QC4.10 IP67		
Junction box	IP 67	IP 67	IP 67
Fire class	C	C	C
Module fire performance	Type 4	Type 4	Type 4
Design Load(Pa)	3600	3600	3600
Max Test Load(Pa)	5400	5400	5400

WSP-MX 6X10

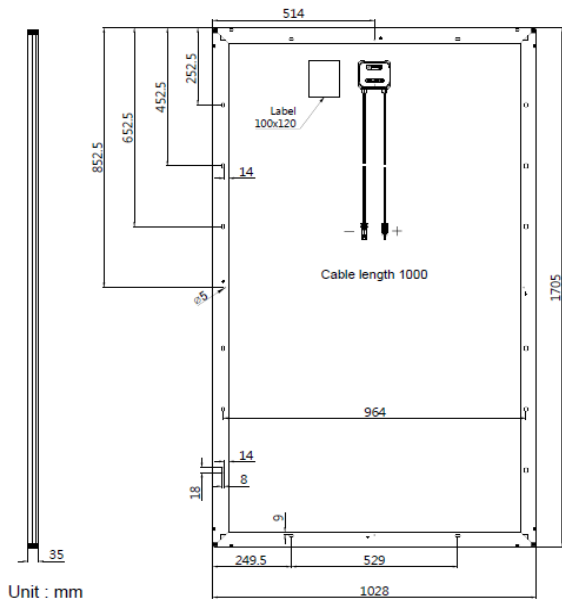

WST-P6 6X12

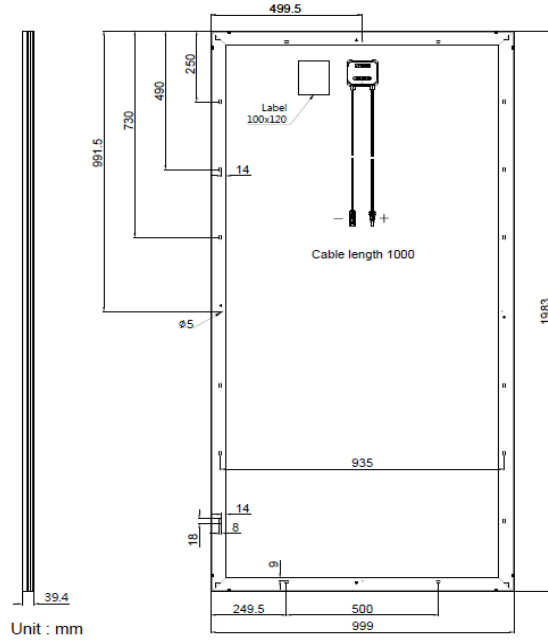

WSP-P6 / WSP-M6 6X10

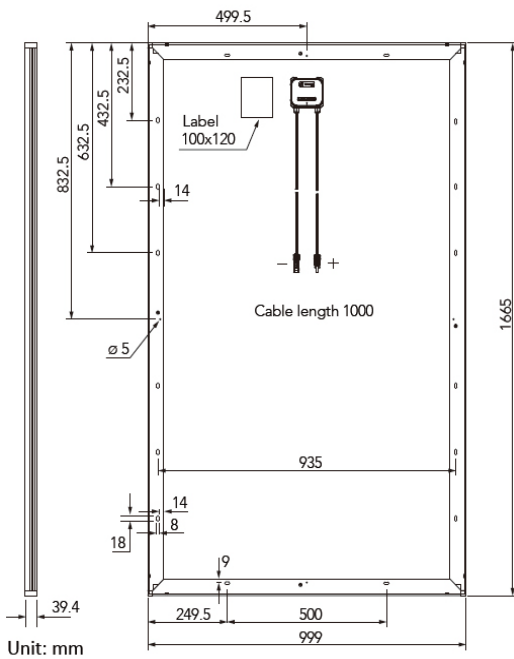

WST-P6 / WST-M6 6X10

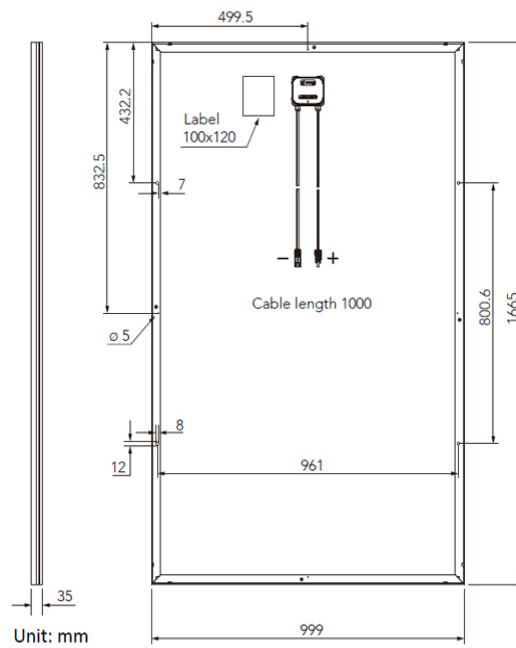

WST-M6 6X8

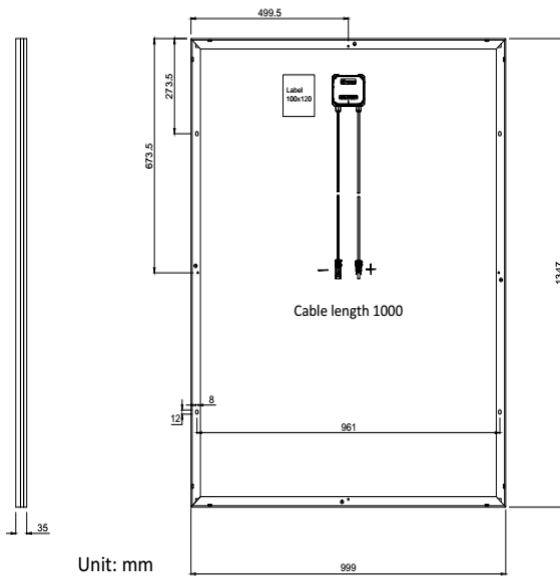

3. Warning notices and handling instructions

Warning notices



ATTENTION:
Danger of death from electric shock.

Solar modules start to generate electricity as soon as they are exposed to light. It is hazardous to your health to touch a module with a voltage of 30 volts or more. Every series or parallel connection of the modules increases the voltage or electric current respectively. Series connection of more than two solar modules can generate life-threatening voltages: **High voltage!** The fully insulated plug-in contacts do provide insulation protection. However, you should nevertheless observe the following when handling photovoltaic modules:

- Do not insert electrically conductive parts into the plugs and sockets.
- Do not install solar modules and wiring with wet plugs and sockets. Working conditions and tools must be dry.
- All work performed on the wiring must be carried out by authorised specialist personnel with the utmost caution and only with the aid of safety equipment.
- High voltages may be present in wiring, modules and inverters even when they are switched off. Undertake all work with the appropriate level of caution – **risk of death due to electric current!**
- After switching off the inverter, before beginning any further work it is essential to wait for the time interval specified by the manufacturer so that the high-voltage components can discharge.
- Be sure to carefully follow the inverter manufacturer's installation instructions!

WINAICO modules are designed to meet the requirements for the IEC 61215, IEC 61730 and UL 1703 standards for operation in a temperate climate (the module operating temperatures are between -40 °C and +85 °C). Hazardous voltages (IEC 61730: higher than 50V DC; EN61730: higher than 120V DC), hazardous power applications (higher than 240W) where general unrestricted access is anticipated. Modules qualified for safety through EN IEC 61730-1 and 61730-2 within this application class are considered to meet the requirements for Safety Class II).



ATTENTION:
Danger of death from electric arcs

Modules generate direct current (DC) when exposed to light irradiation and a deadly electric arc can result when opening a closed section (e.g. when separating the DC cable from the inverter under load).

Product protection

Protect the modules from incorrect handling.

- Do not lay any objects on the modules, never walk on the modules and do not drop them.
- Only undertake modifications on the module if these have been confirmed in writing by WINAICO.
- Do not work on the modules with pointed objects.
- Keep all electrical contacts clean and dry.
- It is recommended that the serial numbers be noted for system documentation.
- The solar module is not saltwater-resistant, and shall not be in direct contact with salt water.
- The module must not be subjected to unusual chemical loads (e.g. emissions from manufacturing plants).
- Do not use lenses or mirrors to concentrate light (danger of overheating).
- If solar modules are to be connected to storage batteries, the safety precautions of the battery manufacturer must be observed.
- Do not stand or step on the PV module, this is prohibited. There can be risk of micro-crack which may cause a sharp decline of module's power performance; what's more, it may threaten your safety.
- Do not hit or put excessive load on the glass or back sheet. There can be risk of micro-crack which may cause a sharp decline of module's power performance; what's more, it may threaten your safety.

Under the anticipated conditions, a PV module can supply a higher current and/or voltage than specified in the standardised test conditions. The voltage rating of components, current rating values of conductors, fuse sizes and rating of controllers connected to the outputs of PV modules should be at least 1.25 times the module I_{sc} and V_{oc} . For systems installed in North America, refer to Section 690-8 of the National Electrical Code for an additional 1.25 multiplying factor where applicable. The highest rating value for the overcurrent protection (reverse-current strength) is 20 A.

4. Transport, storage and unpacking





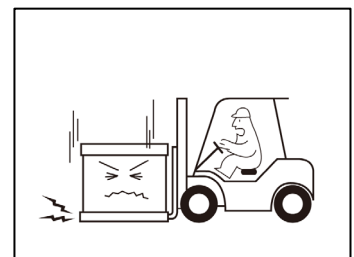
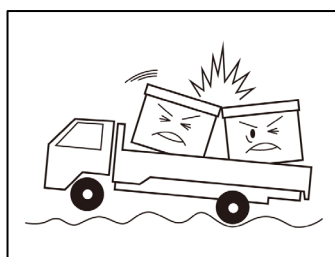

Check the shipment immediately upon delivery to ensure completeness and integrity. Note any damage on the driver's consignment note and inform WINAICO in writing immediately. The utmost care is required when handling the modules. Take care when transporting, storing and unpacking them, please see the caution on the module carton. For your safety, do not disassemble or modify the WINAICO PV modules in any way.

Transport and storage

- Avoid collision and shock during transportation.
- Do not drop, handle with care during transportation.
- Store the modules safely in cool and dry rooms. The packaging is not weatherproof!



- Leave modules in their packaging until they are to be installed.
- Do not stack more than 2 pallets high.
- Do not set the modules down roughly on hard ground and the module corners.

	THIS SIDE UP		HANDLE WITH CARE
	KEEP DRY		DO NOT STEP ON IT
	FRAGILE		DO NOT STACK

Unpacking

- During the module unpacking, request two people to operate together and gently pulling the 1st module with both hands.
- Avoid horizontal movement when lifting module.
- Carry the modules with both hands and wear safety gloves or use glass suction cups for removal and transport.
- Under no circumstances use the junction box or connection lines as handles.

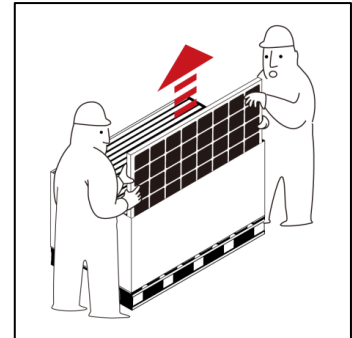

5. Application area and mounting site

Application area

- The module is intended for use in temperate climatic conditions. The extreme weather temperature might affect the power output and efficiency of the solar module.
- The module must not be exposed to concentrated light. It must not be immersed in water or constantly exposed to water spray (e.g. from fountains).
- There is risk of corrosion with exposure to salt and sulphur (sulphur sources, volcanoes). Therefore, the module must not be installed in the vicinity of salt, salt water and sulphur.
- The permissible module temperatures are between -40 °C and +85 °C.
- Sufficient ventilation from behind the module should be ensured to prevent raised module temperatures.
- Do not subject modules to strong chemicals.
- Make sure that the modules and module components are never standing or lying in water.
- The module may not be installed adjacent to naked flames or flammable materials. Solar modules are non-explosion-protected equipment.

Mounting site

- Orientation
The solar module should be mounted facing towards the south (Northern Hemisphere) if possible. This results in the best energy yield. Alternatively, the solar module can be orientated towards the path of the sun. The gradient of the modules should be at least 15°. In Central Europe a gradient of 30° is optimal.
- Location
The mounting site should be as free as possible from shade of any kind (houses, trees, branches, leaves, cables, antennas, etc.), because shade can significantly reduce the output of the solar modules. Partial shade can also reduce the energy yield. A module is regarded as free of shade if the entire surface is free of shade throughout the year, and with unhindered exposure to sunlight over a period of several hours per day, even on the most unfavorable days of the year.
- Ventilation from behind
Solar modules produced by all manufacturers decrease considerably as the modules heat up. Ventilation from behind mitigates the effect of performance reduction in heat. This is especially true for our modules with a

black sheet and a black frame. For this reason, sufficient space between the modules and the roof surface must be ensured during mounting to provide sufficient cooling of the modules with air circulation.

- Winter
When mounting a module it is essential to ensure that the water drainage openings at the corners of the module are not covered, in order to avoid damage from frost. The solar installation should be mounted such that as little snow as possible can remain on the modules. Solar modules from WINAICO are certified for snow loads up to 5400 Pa.

6. Mounting and installation



ATTENTION:
Risk of fire if module components are damaged!

- Only install undamaged solar modules.
- Before the installation ensure that the junction box, cables and connectors are undamaged.
- Never open the junction box chassis.

Safety precautions

- Store the modules safely in cool and dry rooms. The packaging is not weather-proof!
- Incorporate the installation in the existing lightning protection system in line with local requirements.
- WINAICO recommends only mounting and installing the system in dry weather.
- Observe the relevant accident prevention regulations.
- Do not carry out installation work in high winds.
- Secure yourself and other persons against falling.
- Prevent the possibility of falling objects.
- Secure the work area so that no other persons can be injured. Keep children away from the installation site.
- All parts of the module should be protected from mechanical stress (e.g. caused by pressure, tension, torsional stress) during transport and installation. Ensure that the radius doesn't fall below the minimum permissible bend radius of 60 mm for cables at the junction box output either during installation or system operation.
- Do not damage, pull, bend, or place heavy material on cables.

Fire protection

The installation of on-roof systems can affect the fire safety of a building; improper installations can be a fire hazard. In the case of on-roof applications, the WINAICO modules must be mounted above a fire-resistant surface.

The module is “non-explosion-protected equipment”. The use of improper installation methods and/or defective parts may result in the unexpected occurrence of an electrical arc during operation. Therefore, it may not be installed near highly flammable gases and vapours (e.g. filling stations, gas tanks or paint spraying systems). The module may not be installed adjacent to naked flames or flammable materials.

6.1 Mechanical module mounting

WINAICO modules are suitable for both vertical and horizontal installation methods due to their high degree of stability. The modules must be clamped in place at a minimum of 4 points. The frame has only been stress tested for fastening by the long sides. Therefore always clamp the modules on the long sides only. The modules must always be installed with the junction box pointing upwards, such that the junction box is located on the rear side of the module in the

upper section.

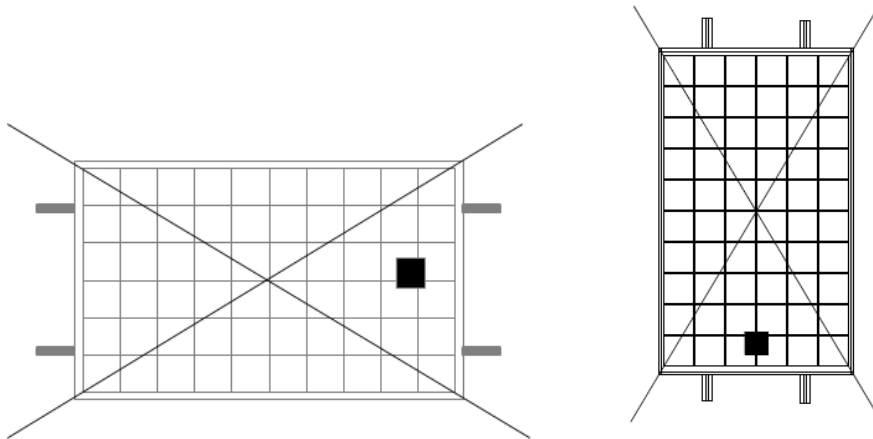

Examples of incorrect installations: left) clamping on the short sides, and right) reverse installation with junction box pointing downwards, are not permitted.

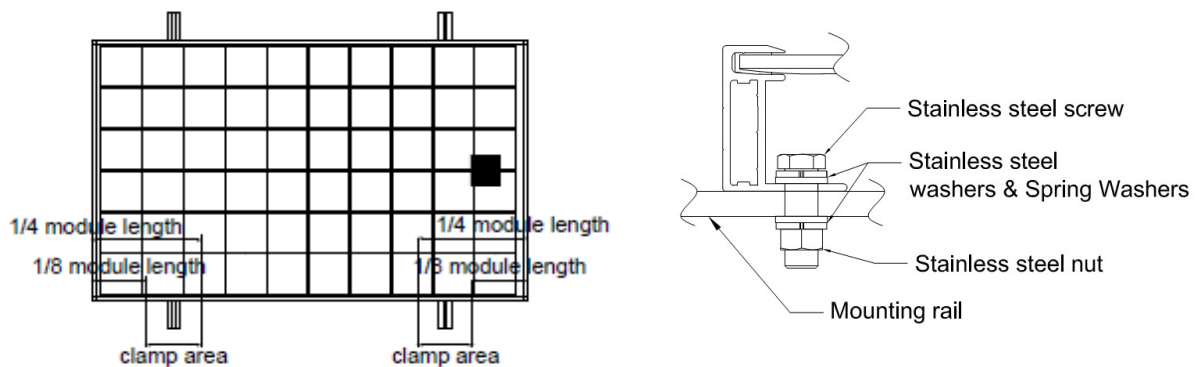

Examples of correct mounting methods: left) clamps can be used only at the specified clamping area, and right) mounting with screws.

The modules can be mounted on the substructure by clamps from the front or by screws from behind. The clamping area (Figure above) for each fastening point must have an area of at least 135 mm². A torque wrench must be used for assembly. In the examples shown, the tightening torque (using M8 bolts produced from V2A) is 20 Nm. Use the existing drilled holes for securing the module. Do not drill any additional holes (doing so will void the product warranty). Use appropriate corrosion-resistant fastening materials and use washers to fasten the PV module.

Maximum mechanical load

Ensure that the maximum mechanical load is not exceeded, also taking into account any site-dependent loads (See point 2 module description). Please note that the module can bend under heavy loads. Do not use cable ties or other fastening elements on the rear side of the module, because uneven structures can damage the modules.

Note

The middle clamps can be used as spacers between the module rows when mounting the modules. To avoid any possible stresses and failure to comply with dimensions, a gap should be maintained between the module rows. We recommend a gap of approximately 2 cm. For aesthetic reasons we recommend using black clamps for mounting our

module series with black anodised frame and black backsheet. Do not touch live terminals with bare hands, and always use insulated tools for electrical connections.

Laying the cables

To avoid conductor loops, the strings (+ and –) should be laid together. Cable trays can be used if required. Roof penetration should be minimised to one if possible. PVC cables are not recommended. Bare copper H07RN cables are not recommended because the contact resistance of crimping location will probably exceed the permitted value as the copper wires oxidise over time. WINAICO recommends installers to use only sunlight resistant cables qualified for direct current (DC) wiring in PV systems. The minimum wire size should be 12 AWG.



ATTENTION: Lightning protection is recommended for PV systems that are to be installed in locations with high probability of lightning strikes.

6.2 Electrical installation

Module selection

Ensure the module meets the technical requirements of the system as a whole. Ensure that other system components do not exert damaging mechanical or electrical stresses on the module. When connected in series, modules must all have the same current rating. When connected in parallel, the modules must all have the same voltage rating. The modules must not be connected together to create a voltage higher than the permitted system voltage. Modules must not be fitted as overhead glazing or vertical glazing (façade). Ensure that the mounting system can also withstand the anticipated loads, e.g. wind and snow loads. There are openings at the base of the module frame to allow water from precipitation to drain away. Ensure that the functionality of these openings is not restricted by the module installation.

Diodes and fuses

The shading of individual solar cells or solar modules can lead to the shaded area heating up because the shaded area begins to consume electrical energy, as opposed to generate energy in unshaded parts. The use of bypass diodes or other technical elements to bridge the shady areas results in a reduction in the heating process, and mitigates the performance losses of the respective PV system. WINAICO solar modules are factory-fitted with integrated bypass diodes or other design elements, which offer efficient protection to the solar cells. Bypass diodes are not overcurrent protection devices.

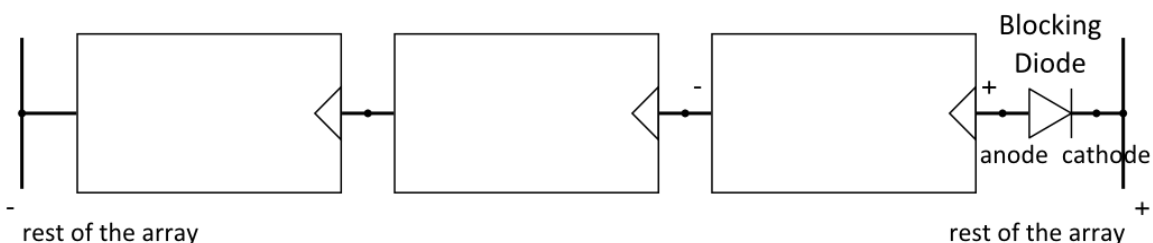

If it should be necessary to connect the module strings in parallel then please proceed as follows:

- Select one of the module strings requiring parallel connection.
- Connect a suitably rated blocking diode in series with the module string, forward biased in the direction of the generated current flow. In order to achieve this, the diode anode is connected to the positive (+) terminal of this string. The blocking diodes are designed to conduct the full string current when the modules are active.
- Once work on the first module string is complete, repeat this process for all of the other strings to be

paralleled together. Then establish the requisite connections for the parallel interconnection of these strings. In place of the additional diodes it is also possible to install direct current string fuses. If shading of individual module strings within a parallel circuit is expected, diodes are preferable.

The installation of additional diodes or fuses is necessary with the parallel connection of module strings because the integrated bypass diodes are only rated to each module, and are not able to adequately regulate the current flow in a parallel circuit in the event of the shading of individual module strings. A failure to comply may result in the corresponding solar modules (including the electronic components contained within them) being damaged.

WINAICO recommends the installation of DC fuses with both series and parallel type connections, in order to protect the solar modules in the event of a malfunction (e.g. an inverter defect). The fuses must be configured according to the maximum series fuse rating, which is quoted in the data sheets pertaining to the respective modules.

Cables and connectors

A PV module has a pair of male and female waterproof connectors.

- Connect the output cable to the other equipment in the system correctly.
- Connect the required number of PV modules to meet the voltage specification of other equipment used in the PV system.
- Wire the output cable connectors so they do not exert any force or pressure on the PV module's junction box. Attach the cable to the mounting frame using approved fasteners. The connectors should be placed behind the mounting frame so that the connectors can't be directly exposed to sunlight, wind and rain.
- To extend the cable, use proper commercial cables and connectors that can withstand outdoor use for long periods. Select the appropriate cable size according to its length to avoid voltage drop.



ATTENTION: WINAICO connectors' protection level is IP67. They cannot be under water for a long time. Sunlight exposure and immersion in water of the connectors should be avoided. Do not allow installed PV connectors and cables to be in contact with the roof surface or the ground.



ATTENTION: Faulty connections can result in arcs and electrical shock. Check that all electrical connections are securely fastened. Make sure that all locking connectors are fully engaged and locked.

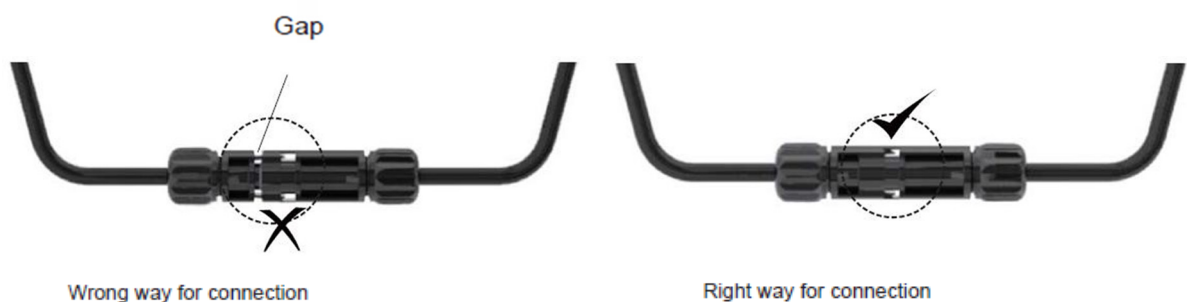

ATTENTION: To prevent electric shocks, please turn off the power when installing PV connectors. Do not pull apart the PV connector under load. Turn off the DC/AC inverter or turn on DC circuit breaker to disconnect PV connectors from load. Then insert and extract under voltage is permitted.



ATTENTION: The cable must not be bent or crushed at the joints to connectors and junction box. A minimum bending

radius $R \geq 5 \times$ cable diameter must be maintained. The cable must be routed in a way that tensile stress on the conductor or connection is prevented.

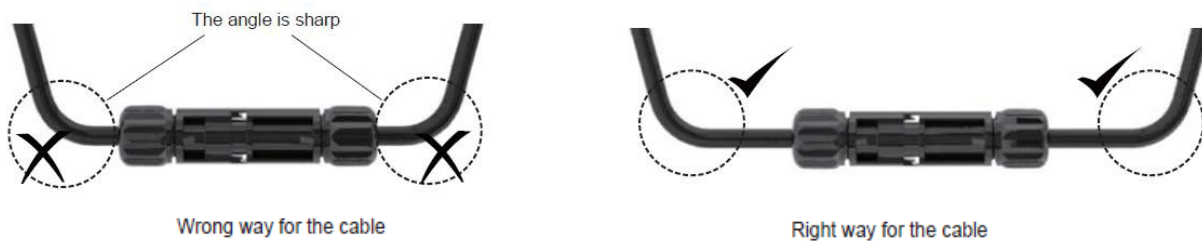

*Please refer to the detailed instructions of the minimum bend radius given by manufacturer.

Safety precautions



ATTENTION:

Please ensure the correct connection of the sockets and sleeves.

Do not cut the module cable connectors. The strings (+ and – cables) are fed into the inverter via the DC solar inputs. The polarities of the module connectors are specified. The cable on the + connector of the module should be connected to the inverter at the + input. The same procedure applies to the – connector and – inverter input. The cables can lie in cable trays. It is important to make sure that no water remains in the cable trays, which could happen on uneven roofs. Holes can be drilled into the trays to facilitate drainage. Only certified socket connectors can be used to connect the solar cables to the modules and inverters. The socket connectors are crimped on with special pliers or connected to the modules and inverters with adapter cables. The adapter sets are connected to the (approximately 6 mm stripped) end of the cable. Then crimp the connection and shrink-fit the shrink tubing over the connection with a hot-air gun or flame. Individual strings can be checked for polarity and voltage with a multi-meter/voltmeter. The inverters should be connected in accordance with the manufacturer's instructions.



ATTENTION:

Depending on design requirements and inverter used, different string lengths are possible. It is essential to follow the assembly instructions for the inverter! Make sure each individual string is de-energised prior to connecting to the inverter. It is absolutely imperative that the inverter is connected to the public grid power by a certified specialist.



ATTENTION:

High voltage direct current can occur even at low levels of radiation. Never touch exposed live cables.

6.3 Grounding

Proper grounding on the module frames is the responsibility of the solar installer. Grounding must be performed by an authorised installer for the safety and maintenance of the system in accordance with all national, state and local electrical codes and regulations and standards.

Proper grounding is achieved by connecting the module frame(s) and structural members contiguously using a suitable "grounding conductor". Careful selection of the grounding components dictates that when using connecting different materials together, they shall not lead to galvanic corrosion of one another. As such, when using copper hardware, contact with the aluminium frame shall be avoided. For North American customers, the grounding conductor, or strap, may be copper, copper alloy, or other materials acceptable for use as an electrical conductor per NEC. The grounding conductor must then make a connection to earth using a suitable earth ground electrode.

If an external lightning protection system is already provided or planned for the building, the photovoltaic system must be integrated into the system to protect against direct lightning strikes. When using transformer less inverters, grounding should be carried out for personal safety reasons. The grounding hole is marked on the module frame.

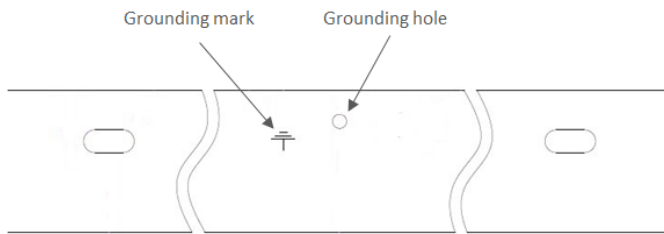

For grounding purposes, an M4 stainless screw, nut and washer are used. PV modules have an anodized coating on aluminium frames for corrosion resistance. In order to properly ground the modules frames, the coating must be penetrated. Please observe the national standards when grounding. If national standards do not require grounding, WINAICO still recommends all PV module frames to be grounded to ensure the voltage between electrically conductive equipment and earth ground is zero in all circumstances.

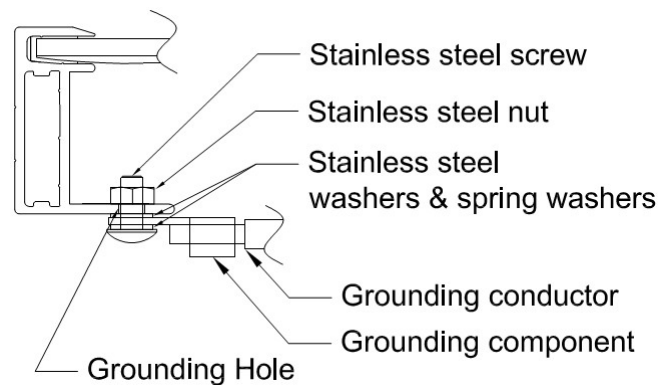

When installing in North America, a module with exposed conductive parts is considered to be in compliance with UL 1703, only when it is electrically grounded in accordance with the instructions presented above and the requirements of the National Electric Code. Where common grounding hardware (nuts, bolts, star washers, split-ring lock washers, flat washers and the like) is used to attach a listed grounding/bonding device, the attachment must be made in conformance with the grounding device of manufacturer's instructions. Common hardware items such as nuts, bolts, star washers, lock washers and the like have not been evaluated for electrical conductivity or for use as grounding devices and should be used only for maintaining mechanical connections and holding electrical grounding devices in the proper position for electrical conductivity. Such devices, where supplied with the module and evaluated through the requirements in UL 1703, may be used for grounding connections in accordance with the instructions provided with the module.

7. Cleaning and maintenance

As the operator, you should regularly remove dirt from the modules and check if all system components are functioning properly. The following points should be noted:

- Never stand on the module surface. Do not exert any mechanical load on the modules.
- Do not clean with water if there is a risk of frost or major differences in temperature between the module,

water and air.

- We recommend decalcifying hard water. This will prevent lasting water stains. Remove standing water from the module.
- Do not use abrasive cleaning agents or detergents. Do not scrape off dirt as this may damage the surface of the module.
- Check if all cables and connector accessories are undamaged and properly secured.
- PV modules are not shaded by unwanted obstacles or any foreign material.
- Mounting and grounding components are tightly secured with no corrosion.



ATTENTION:

Please make sure that the earth connection is not interrupted or damaged!



ATTENTION: WINAICO recommends PV systems to be periodically inspected by the installer, or other qualified person.

8. Liability disclaimer

These installation and assembly instructions apply in general to standard systems. No responsibility is accepted for the correctness of this information. WINAICO does not provide any guarantee of the usability and serviceability of the modules if the user fails to observe this user information. As compliance with this user information and the conditions and methods for the installation, operation, use and maintenance of the modules from WINAICO cannot be checked or monitored, WINAICO shall assume no liability for damages resulting from improper use, faulty installation, operation, use or maintenance. In addition, no liability shall be borne for infringements of patent laws or other rights of third parties which result from the use of the modules, unless mandated by law.

9. Contacts

If you have any questions, our WINAICO Team is available to assist you at all times:

Taiwan Headquarters

Win Win Precision Technology Co., Ltd.

4F., No.180, Sec. 2, Gongdao 5th Rd., East, Dist. Hsinchu City 300, Taiwan

info@w-win.com.tw

WINAICO Deutschland GmbH

Industriestraße 68, 97993 Creglingen

Germany

Phone: +49 7933 700 300

germany@winaico.com

WINAICO UK Ltd.

WINAICO UK Ltd

Bloxham Mill Business Centre

Barford Road, Bloxham

Banbury OX15 4FF

United Kingdom
Phone: +44 (0)1295 722833
uk@winaico.com

WINAICO Australia Pty Ltd
3/393 George Street, Sydney NSW 2000
Australia
Phone: +61 2 8091 2771
australia@winaico.com

WINAICO USA
505 Keystone Road Southampton, PA 18966 USA
Phone: +1 844 946 2426
usa@winaico.com

WINAICO Japan KK
7F Humax Ebisu Building, Ebisu Minami 1-1-1, Shibuya-ku 150-0022 Tokyo
Japan
Phone: +81 (0) 3 5456 5798
japan@winaico.com



WINAICO is a trademark of
Win Win Precision Technology Co., Ltd.

Version 26/OCT/2018